

Cartridge-Filtereinsätze

Ausführung ohne O-Ring

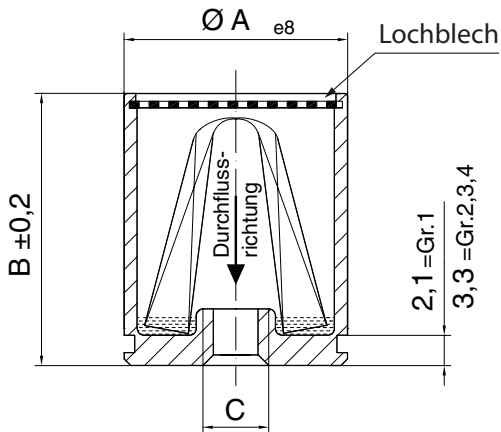

Ausführung mit O-Ring

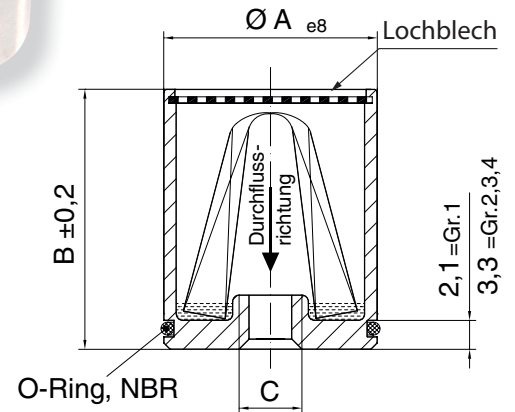

Werkstoffe

Metallteile: Edelstahl

für Ø A erforderlicher Bohrungs-Ø H7

Filtergewebe: Drahtgewebe und Metallfaservlies

max. Δp 20 bar

Grösse	Bestell-Nr.	Feinheit in µm	ØA	B	C
1	41017	5	17,0	20,7	M6
	41005	10			
	41001	25			
	41002	40			
	41003	60			
	41004	100			
2	41018	5	20,0	22,0	M8
	41016	10			
	41011	25			
	41012	40			
	41013	60			
	41014	100			
3	41019	5	25,0	26,0	M10
	41020	10			
	41021	25			
	41022	40			
	41023	60			
	41024	100			
4	41029	5	30,0	30,0	M14
	41030	10			
	41031	25			
	41032	40			
	41033	60			
	41034	100			

Grösse	Bestell-Nr.	Feinheit in µm	ØA	B	C
1	42017	5	17,0	20,7	M6
	42005	10			
	42001	25			
	42002	40			
	42003	60			
	42004	100			
2	42018	5	20,0	22,0	M8
	42016	10			
	42011	25			
	42012	40			
	42013	60			
	42014	100			
3	42019	5	25,0	26,0	M10
	42020	10			
	42021	25			
	42022	40			
	42023	60			
	42024	100			
4	42029	5	30,0	30,0	M14
	42030	10			
	42031	25			
	42032	40			
	42033	60			
	42034	100			



microfilter gmbh

Robert-Bosch-Straße 9 • D-74632 Neuenstein

T: +49 (0) 79 42/756 30-0 • F: +49 (0) 79 42/756 30-290

www.microfilter.de • info@microfilter.de

Freimaßtoleranzen nach DIN ISO 2768-m
V3.1 (Stand 14.01.2013)

Technische und maßliche
Änderungen vorbehalten